

TRITORC

PIPELINE SOLUTIONS

OD-MOUNTED PIPE CUTTING & BEVELLING EQUIPMENT

TCSL OPERATION MANUAL

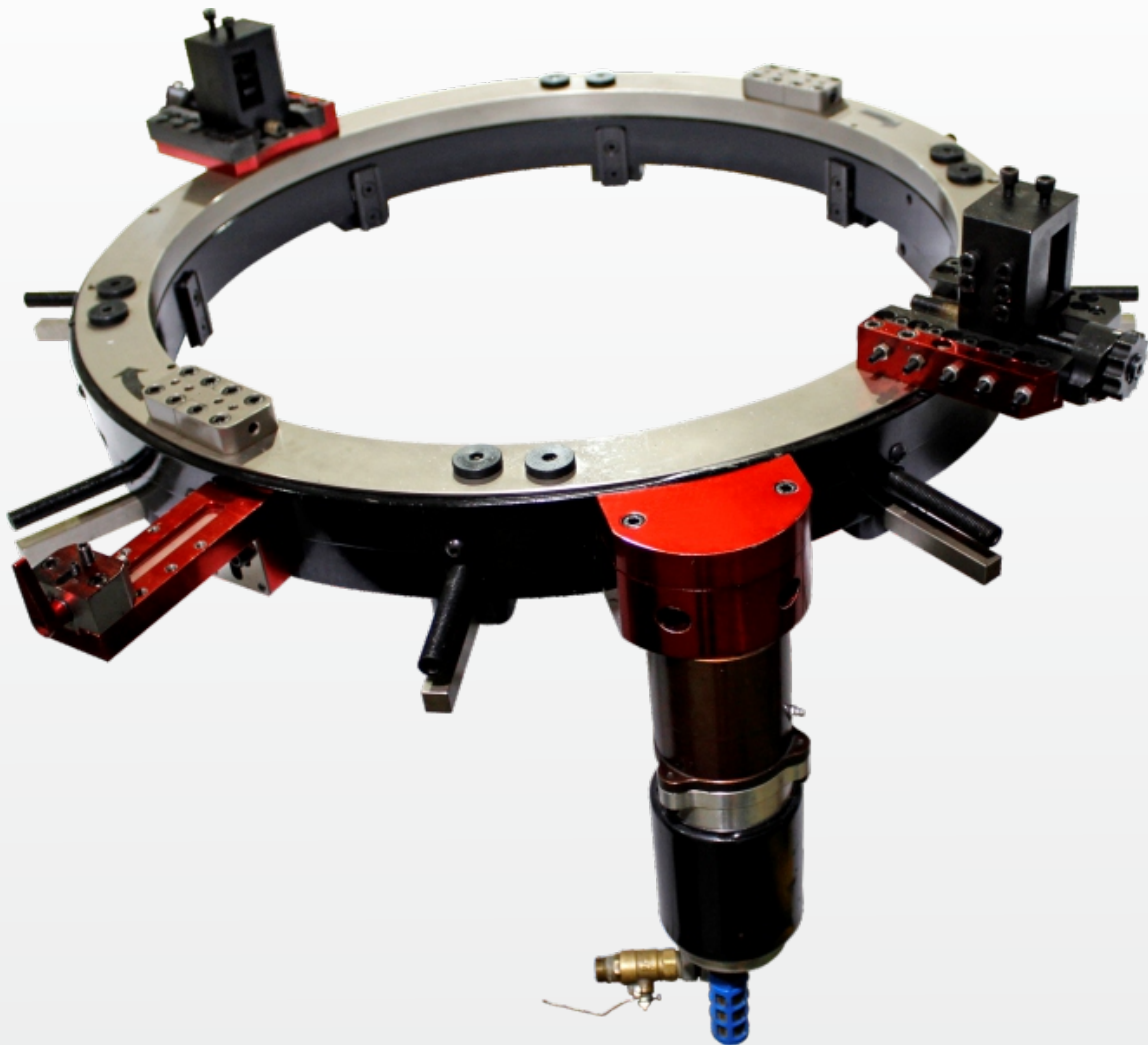

TABLE OF CONTENTS

SAFETY PRECAUTIONS:

GENERAL SAFETY INSTRUCTION	03
MACHINE SPECIFIC SAFETY PRECAUTIONS	03
RISK ASSESSMENT AND HAZARD MITIGATION	04
PNEUMATIC DRIVE SAFETY INSTRUCTION	04

INTRODUCTION:

GENERAL DESCRIPTION:	05
MACHINING FUNCTION & CAPACITIES:	05
DRIVE ASSEMBLY.	05
TOOLING	05
T42 TOOLING CHART	06

COMPONENTS:

HOUSING	07
ROTATING RACK RING ASSEMBLY	07
GEAR BOX DRIVE ASSEMBLY	07
BEARINGS	07
TOOL POST SLIDE ASSEMBLY.	07
TRIPPER ASSEMBLY	07
UNIVERSAL LOCATOR ASSEMBLY	07

MACHINE SET-UP:

PRE-INSTALLATION PROCEDURE	08
--------------------------------------	----

OPERATING PROCEDURE:

PRE-OPERATION CHECKLIST	10
INSTALLATION ON IN-LINE PIPE	10
SQUARING & CENTRING	10
SETTING TOOL BITS.	11

MOTOR INSTALLATION 12

MACHINE OPERATION:

SEVERING IN-LINE PIPE:	13
SEVERING AND BEVELLING IN-LINE PIPE:	13
MACHINE REMOVAL:	13

MACHINE MAINTENANCE:

TOOL POST ADJUSTMENT.	14
ADJUSTING THE BEARINGS.	15
BILL OF MATERIAL.	16
TROUBLESHOOTING	17

PART LIST (ASSEMBLY DRAWINGS):

MAIN ASSEMBLY	18
GEAR BOX ASSEMBLY	19
TOOLPOST ASSEMBLY	20
TRIPPER ASSEMBLY	21
UNIVERSAL LOCATOR ASSEMBLY	21
ROTATING ASSEMBLY	22

SAFETY PRECAUTIONS

GENERAL SAFETY INSTRUCTION

01. **DO NOT RUSH THE JOB!** Read and understand the instructions before operating the machine.
02. If there is a question on safety, or if technical expertise is required, call for technical support.
03. Wear appropriate protective safety equipment including: Safety Glasses, Gloves, Hard Hat, Protective Shoes, Hearing Protection, Hair Restraints, and Coveralls.
04. Keep loose clothing, long hair, or any other unsecured part away from operating machines.
05. Keep the work site clean. Use a brush to remove chips from the work piece. **DO NOT** use your hands or an air hose to remove chips and swarf.
06. Ensure adequate workspace around work area before mounting the Machine.
07. Support work material for total machine weight.
08. Before connecting the power source to the Machine, make sure the following items are tightly secured:
 - Machine Split Line Feed Pin
 - Tool Blocks Tool Bit
 - Locator Pad Motor Mount
09. **KEEP HANDS AWAY FROM MACHINE WHEN OPERATING!** Adjustments should only be made when the rotation has stopped and the power is disconnected.
10. **NEVER** move or work on the Machine without first isolating the power source.
11. **ALWAYS CLOSE CONTROL VALVES IF A POWER FAILURE OCCURS!**
12. **NEVER MOVE THE MACHINE WHILE CONNECTED TO THE POWER SOURCE!!!** Disconnect air hose or hydraulic power before moving or removing the machine from the work piece.

MACHINE SPECIFIC SAFETY PRECAUTIONS

EYE HAZARD – This machine produces metal chips during operation. Always wear eye protection when operating the machine.

SOUND LEVEL – This machine produces potentially harmful sound levels. Hearing protection is required when operating this machine or working around it.

HAZARDOUS ENVIRONMENTS – Do not operate the machine in environments where potentially explosive materials, toxic chemicals, or radiation may be present.

MACHINE MOUNTING – Do not operate the machine unless mounted to a work piece in accordance with this manual. If mounting the machine in an overhead or vertical position, do not remove hoist rigging until the machine is mounted to the work piece in accordance with this manual.

RISK ASSESSMENT AND HAZARD MITIGATION

- Machine Tools are specifically designed to perform precise material-removal operations.
- Stationary Machine Tools include lathes and milling machines and are typically found in a machine shop. They are mounted in a fixed location during operation and are considered to be a complete, self-contained machine. Stationary Machine Tools achieve the rigidity needed to accomplish material-removal operations from the structure that is an integral part of the machine tool.
- In contrast, Portable Machine Tools are designed for on-site machining applications. They typically attach directly to the work piece itself, or to an adjacent structure, and achieve their rigidity from the structure to which it is attached. The design intent is that the Portable Machine Tool and the structure to which it is attached become one complete machine during the material-removal process.
- To achieve the intended results and to promote safety, the operator must understand and follow the design intent, set-up, and operation practices that are unique to Portable Machine Tools.
- The operator must perform an overall review and on-site risk assessment of the intended application. Due to the unique nature of portable machining applications, identifying one or more hazards that must be addressed is typical.

PNEUMATIC DRIVE SAFETY INSTRUCTION

When using a pneumatic motor, make sure the pneumatic valve handle is locked in the “off” position (see Figure 1 below) when not in use. Make sure the pneumatic valve lever operates properly before running the machine. If the pneumatic valve is operating properly, the motor will not run unless the pneumatic valve lever is turned to the “on” position.



Fig 1. Closed Position



**NEVER PERMANENTLY LOCK THE PNEUMATIC VALVE
LEVER DOWN. DOING SO COULD RESULT IN SERIOUS INJURY!**



Fig 2. Open Position

INTRODUCTION

GENERAL DESCRIPTION:

The TCSL Series Machines are portable pipe lathes designed to simultaneously sever and bevel in-line pipe, plus form machine any angle bevel as they cut. These tools are portable machines that are strong enough to cut and bevel heavy wall pipe and rigid enough to reface worn flanges. The frame is split for easy installation and the tool bits automatically feed into the work piece with each rotation of the lathe to assure precision machining.

MACHINING FUNCTION & CAPACITIES:

- Sever In-Line Pipe
- Sever and Bevel In-Line Pipe
- Sever and Double Bevel In-Line Pipe
- Socket Weld Removal

DRIVE ASSEMBLY:





There are many different drives available for the TCSL machines. Figure 3 below shows all of the different drive arrangements.

TOOLING:

6x25x150 mm straight sever bits and 25x25x150 mm bevel/sever high speed steel bits are available. Any angle of bevel or counter bore bit can be designed; Tritorc stocks all standard prep configurations for right and left hand severing and bevelling. Specialty bits can be designed as required. Indexable tooling is also available on request

T42 TOOLING CHART

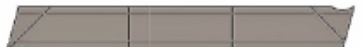
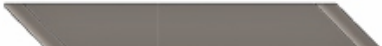
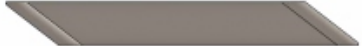
PIPE CUTTING & BEVELLING MACHINE

CUTTING TOOLS			
DESCRIPTION	PART NUMBER	APPLICATION	SKETCH
CUTTING TOOL: Material: HSS T42 Width :25mm Thk : 6mm Length :150mm	PT-BS-RH-6X25X150	Standard Cutting, for most material up to 30mm	
CUTTING TOOL: Material: HSS T42 Width :25mm Thk :6mm Length :200mm	PT-BS-RH-6X25X200	Longer Cutting Tool, both end have blade, for most material up to 60mm cutting job only, with 2C -8200	
CUTTING TOOL: Material: HSS T42 Width :25mm Thk :8mm Length :200mm	PT-BS-RH-8X25X200	Longer Cutting Tool, both end have blade, for most material up to 60mm cutting job only	
BEVELLING TOOLS			
BEVELING TOOL: Material: HSS T42 Width :25mm Thick:25mm Length :150mm	BT-BS-RH- 25X25X150-37.5°	Right Hand Standard Beveling Tool for most materials. Up to 30mm	
BEVELING TOOL: Material: AISI T42 Width :25mm Thk :25mm Length :200mm	BT-BS-RH- 25X25X200-37.5°	Right Hand Standard Beveling tool for most materials, up to 60mm	
COMPOUND BEVELING: Material: AISI T42 Width :25mm Thk :25mm Length :150mm	CBT-SS-RH- 25X25X150-10°-37.5°	Right Hand 10x37.5° as per ASME B[16].25 For most material, up to 30mm	
COUNTER BORING TOOL			
COUNTER BORING TOOL: Material: HSS T42	CBT-15°	For Pipe Counter Boring used on counter boring tool slid	

NOTE: Consult with us for Special Application

COMPONENTS

HOUSING:

An aluminium split ring housing, connected with swing bolts, that is capable of being disassembled for installation on in-line piping. The housing has bearing mountings for the rotating cutting head, a mount for the drive motor assembly, and locator pockets.

ROTATING RACK RING ASSEMBLY:

Made from 4140-alloy steel, this split ring assembly, connected by the gear clamps, will align with the split lines of the housing when the machine is split into halves. The cutting head assembly has gear teeth on the outside diameter of the cutting head and mounting locations for the slide assemblies. An internal bearing race allows the cutting head to rotate about the housing.

GEAR BOX DRIVE ASSEMBLY:

Mounted to the housing and arranged with a pinion gear on a shaft. The motor mounting bracket is designed to accept the reaction torque generated by the drive motor. Alignment keys are used to guarantee perpendicularity between the motor and the cutting head.

BEARINGS:

The cutting head assembly runs on precision bearings that provide for axial and radial force reaction. The bearings are adjustable to compensate for normal wear.

TOOL POST SLIDE ASSEMBLY:

The slide assembly is designed to hold the cutting tool (tool bit). The slide assembly has adjustable gibs and also contains a feed screw assembly, which is used to feed the tool bit into the work piece. The slide assemblies are bolted to the face of the machine assembly and can be moved in 0.2 to 0.4 mm increments.

TRIPPER ASSEMBLY:

The tripper assembly is designed to hold the tripper pin. The tripper pin is used to turn the star wheel on the feed screw assembly, which feeds the tool bit into the work piece. The tripper assembly is bolted to the OD of the housing. There are four different mounting locations that allow for more flexibility in machine mounting.

UNIVERSAL LOCATOR ASSEMBLY:

The alloy steel machine uses adjustable locator assemblies with ½" of travel. Turning set screws located on the outside of the housing actuates the adjustable locators. Locator extensions are required to mount on smaller diameter pipe. Not applicable in case of universal locator assembly.

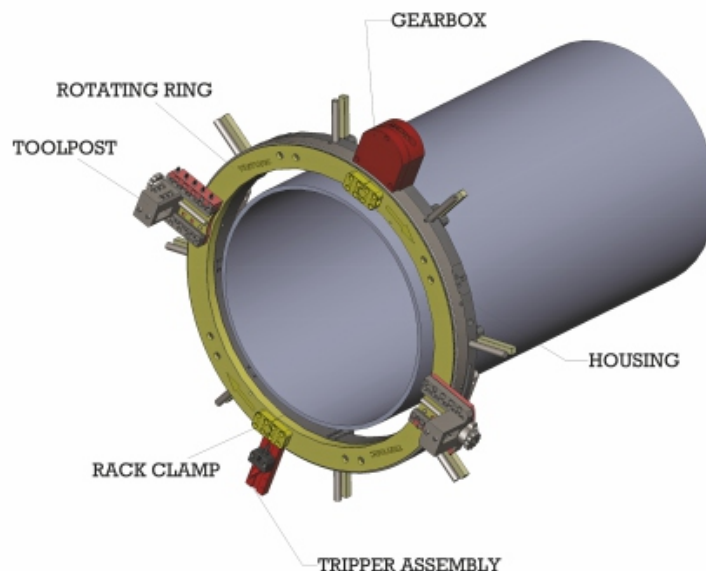

Fig 4.
TCSL Assembly

MACHINE SET-UP PRE-INSTALLATION PROCEDURE

SEPARATING FRAME HALVES:

1. Rotate gear by hand until both the gear and housing split lines are aligned. If the lock pin holes in the gear will not line-up with the holes in the housing, rotate gear 180 degrees for proper alignment.
2. Place the locking pins into the holes through the gear and housing to prevent gear rotation when the machine is split. Press the top button to allow pin to slip into the hole. Make sure there is a locking pin in each half of the machine.



FAILURE TO INSERT LOCKING PINS DURING MACHINE SEPARATION CAN RESULT IN INJURY.

3. Loosen the two swing bolt flange nuts in the housing and swing the bolts out of the pockets. Unscrew the two clamp bolts on the gear halves and separate the machine halves by pulling straight apart.



DO NOT FORCE OPEN USING TOOLS

4. The locator pads are adjusted by turning the set screws that are accessed from the outside of the housing with an Allen wrench. Back-up the locator pads as needed for proper clearance of pipe diameter.



Fig 5. Locator pad

5. Make sure the Slide Assemblies are positioned so they clear the work piece but are as close to the OD as possible (see Figure 6 below). The tool slides have four mounting position and can be changed by removing M8 screws that secure the slide on the rotating ring

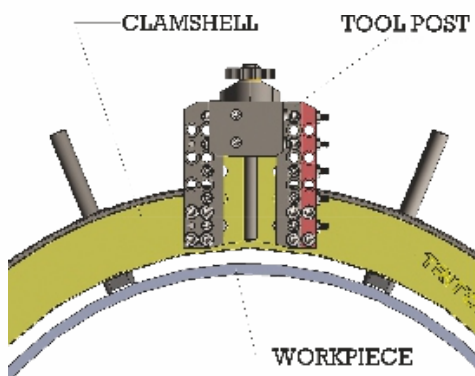
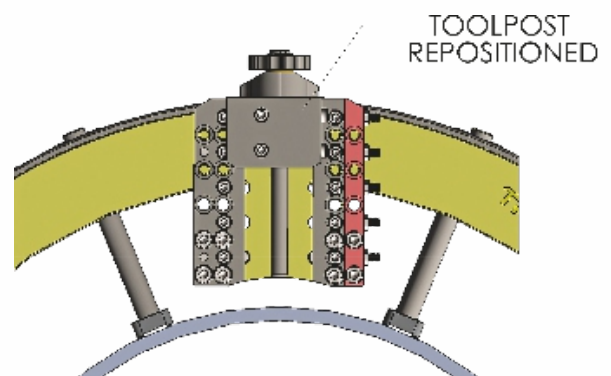

Fig 6.
Tool Post Setup



6. Remove the lock pins. Push the handle of the tripper pin assembly in so the tripper pin is in the “engaged” position. If the tripper pin does not line up with the star wheel, reposition it. After the tripper pin height is set, check the tripper pin length (see Figure 7 below). The end of the tripper pin should be spaced .030” away from the cavity between 2 of the points of the starwheel. Pull the handle to disengage the tripper pin and reinsert the lock pin.

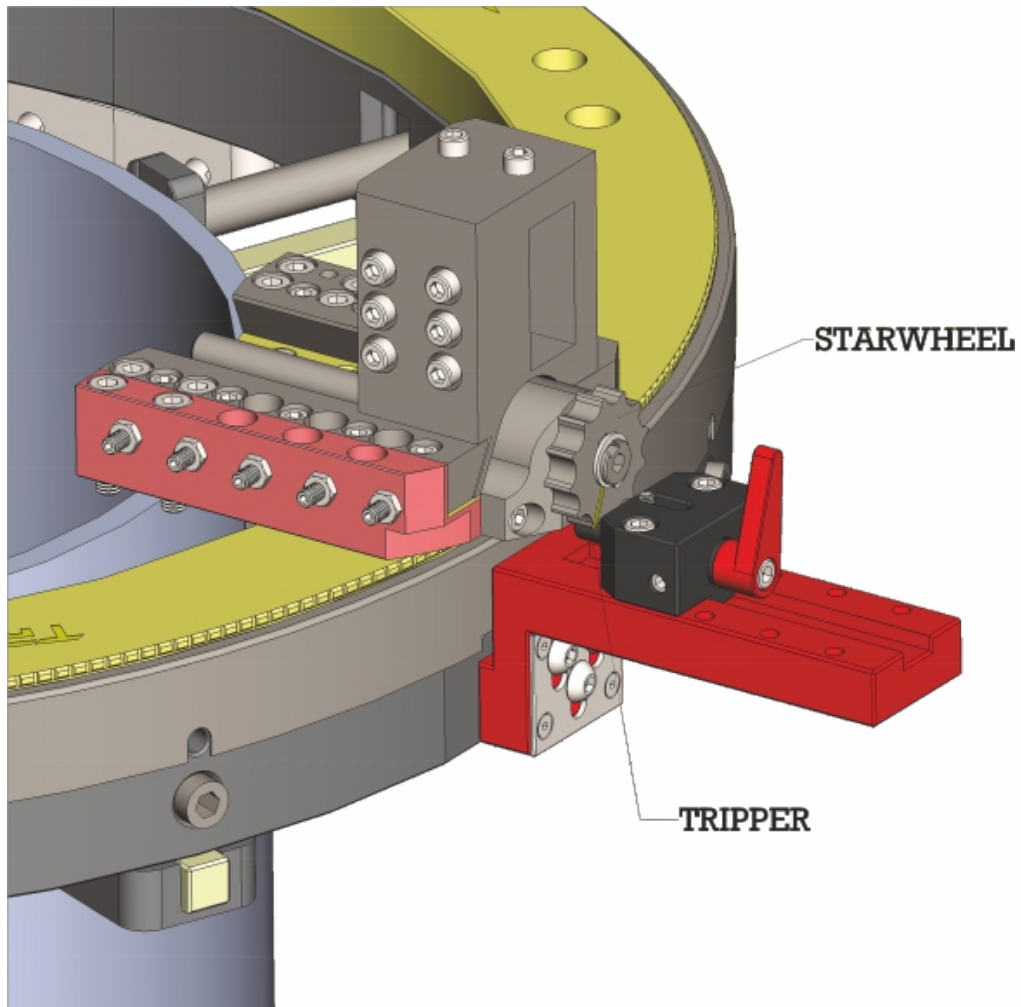

Fig 7. Tripper Setup

OPERATING PROCEDURE

PRE-OPERATION CHECKLIST:

Do the following checks before operating the machine:

1. Check that the work area is clear of non-essential personnel and equipment.
2. Check that the machine control/observation area will not be in the path of hot flying chips during machine operation.
3. Check that the machine is securely mounted to the work piece.
4. Check that air hoses are routed and secured to avoid tripping, entanglement, damage from hot chips, or other damage should an air hose or connection fail.
5. Check the tool condition and sharpness.
6. Check that all hand tools are removed from inside the machine and the work area.

INSTALLATION ON IN-LINE PIPE

Joining Machine Halves:

1. Install the 2 halves of the machine around the pipe and tighten the housing swing bolts and the gear clamp bolts on the cutting head (see Figure 4 above).
2. Lightly tighten two adjustable locator pads directly across from each other (see figure 5), just enough to secure the machine while trying to keep it centered on the work piece. Lightly tighten two more locator pads that are directly across from each other and 90 degrees away from the first set of locators. DO NOT TIGHTEN the locators down completely until the machine has been squared to the pipe.

Note: If Machine will not close, check locator pads for proper size and clearance. Adjust the locators if necessary.

SQUARING & CENTRING:

1. **SQUARING:** Place a Square on the back of the machine, directly in line with a locator, hold the square against the housing and the work piece and square the machine to the work piece at all four locations around the pipe (see Figure 8 below).
2. **CENTRING:** Universal locator assembly have scale to center the machine over pipe. Tighten all the screws such that all scales reads same. Pull out the locking pins so the machine gear can rotate.
3. Mount a dial indicator on the gear face with the tip resting on the work piece OD. Turn the gear so the indicator is positioned over one of the tighten locators (locator 1) and set the dial to zero. Slowly rotate the gear 180 degrees to another locator (locator 2) and take an indicator reading. If the reading is not zero, adjust the locators until the indicator reads one-half of the original reading. Reset the indicator dial to zero and repeat. If the machine cannot be centered, different locators are required.
4. Rotate the gear 90 degrees so the indicator is positioned over another locator (locator 3) and set the dial to zero. Slowly rotate the gear 180 degrees to another locator (locator 4) and take an indicator reading. If the reading is not zero, adjust the locators until the indicator reads one half of the original reading. Reset the indicator dial to zero and repeat. The first two locators may need to be slightly loosened in order to zero the machine to the work piece.

4. Repeat steps 3 and 4 for all of the other locators. The number of locators varies from four to twelve, depending on the model of machine lathe. Most pipe is out of round; therefore, a zero reading all the way around may not be possible.
5. Tighten all remaining locators.

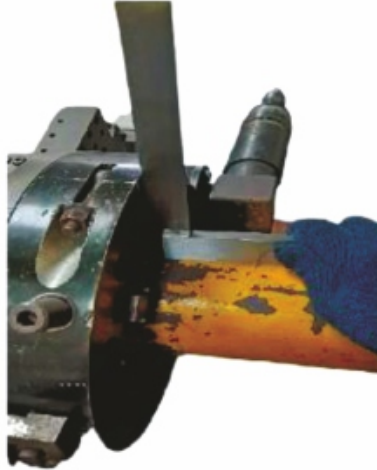

Fig 8. Checking 90o angle

SETTING TOOL BITS:

1. Prior to installation of tool bits, determine which tool bits must be used for your specific machining operation.
2. Using the star wheel wrench, back the tool blocks away from the pipe, to allow enough room for the tool bits to pass completely through the work piece without running the tool blocks into the work piece. Disengage the feed pin, by pulling the tripper handle away from the machine.
3. Insert the proper bevelling and severing bits so that the tip touches the pipe OD and the cutting edge or tip is on centre. Hold the bit with one cap screw, snug but not tight.
4. Manually rotate the cutting head counter clockwise one revolution. This reverse action will push the tool bits away from any high spots in the pipe that could cause tool damage.
5. After one complete revolution has been made tighten the cap screws on both tool blocks. Back the bevel bit 1/32" away from the work piece with the star wheel wrench (see Figure 9).

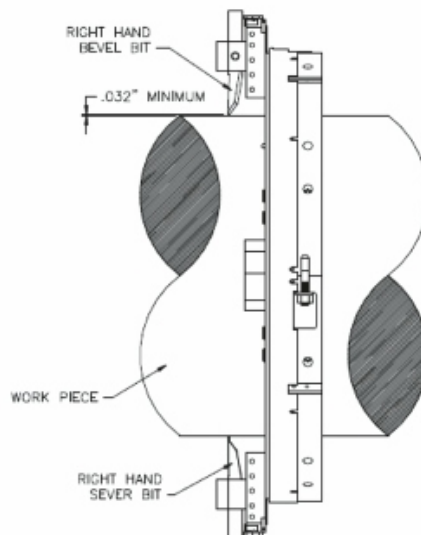

Fig 9. Tool Setup

MOTOR INSTALLATION



Both Locking Pins must be removed from the gear face before installing the motor, and all power must be turned off.

1. Loosen the four motor mount clamp screws. Position the motor mount toward the rear of the machine (see Figure 10).
2. Slide the motor mount under the motor mount clamps and slide the motor forward until the back of the motor mount is flush with the back of the machine housing.
3. If the motor mount does not slide in all the way, rotate the cutter head to align the gear teeth.
4. Tighten the motor mount cap screws.

NOTE: If the motor does not engage, check to make sure the two gears are properly aligned. Rotate the cutting head by hand if necessary to align gear teeth.

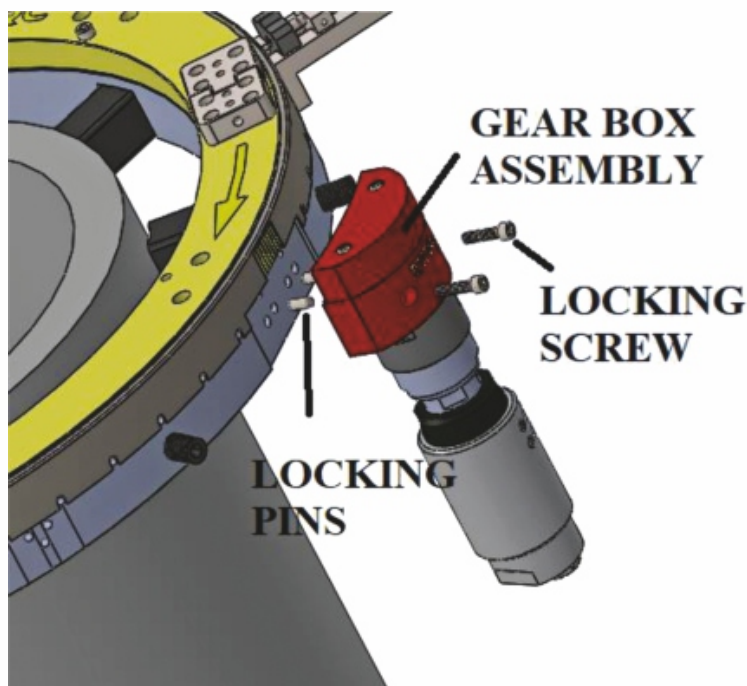

Fig 10. Motor Mounting

NOTE: The Machine cuts in a clockwise direction, when viewed at its face. There are right hand and left hand bevel and sever bits, right hand bits bevel on the side which the machine is mounted, left hand bits bevel on the opposite side.

MACHINE OPERATION



To prevent damage to the tool bit, the work piece to be cut must be rigged properly to keep the tool bits from binding when the pipe is severed. Improperly rigged piping may result in personal injury or equipment damage.

SEVERING IN-LINE PIPE:

NOTE: If the tool blocks do not move smoothly in the slides during the test rotation the adjustable gibs may need adjustment.

1. Follow set-up procedures, using a wide and narrow straight sever bit in opposite tool blocks. Back up both bits (out approx. 1/32"); then back up the wider bit another 2-5 turns of the tripper star wheel, so that it will trail the narrow bit throughout the cut. Attach the drive motor to the machine, disengage the tripper pin, and open the control valve slowly to check function and speed.



The cutting operation is continuous until terminated by the operator. To stop the cutting feed during rotation, **LIFT THE TRIPPER HANDLE** and let the machine rotate a few times to clear the tool bit. Turn off the power to stop machine rotation. Letting the tool bit clear will prevent tool damage and gouging.

2. Engage the tripper pin by pushing down on the tripper handle, after the machine has been started. Each rotation will advance the tool bits approximately 0.08 mm to 0.1 mm with the tripper pin engaged. Use the tripper pin to advance the feed of the tool bits until both of the tool bits are cutting. If chatter or vibration occurs, reduce cutting RPM. If the tool bits chip or become dull, replace them immediately with sharp bits. NEVER TRY TO RE SHARPEN the TOOL BITS, they must be sent back to the factory for regrinding to maintain proper relief angles (DAMAGE TO THE MACHINE COULD OCCUR). Use coolant during the cutting operation to reduce friction on the cutting edge.
3. Stop the machine when the severing is complete. Back out the tool blocks with the star wheel wrench to the full position.

SEVERING AND BEVELLING IN-LINE PIPE:

1. Follow tool bit setup procedures replacing both sever bits with either left hand or right hand SEVER, BEVEL combinations. Back the BEVEL bit up 1/32" above the sever bit and follow the procedure above, until the pipe is severed and bevelled.

MACHINE REMOVAL:

1. Retract tool slide
2. Disconnect power source and remove motor.
3. Loosen the four expanding blocks that holds the split frame in position.
4. Remove split frame from pipe.

MACHINE MAINTENANCE

NOTE: Each tool block slide includes two gibs, which may be adjusted for wear after heavy use. It must always fit exactly parallel to the slide for proper feed screw action.

TOOL POST ADJUSTMENT:

- Before Cutting check the play between holder and side plates. There should be no side to side and up and down play.
- If there is some play then we need to remove this play as mentioned in the below steps.
- First loosen all the screws of the moving plate.
- Loosen all the jam nuts on grub screw.
- Tight the adjustable screws in the following order. Middle screw first and then right and left screws.
- Check the movement of the holder between plates; it should neither too tight nor too loose.

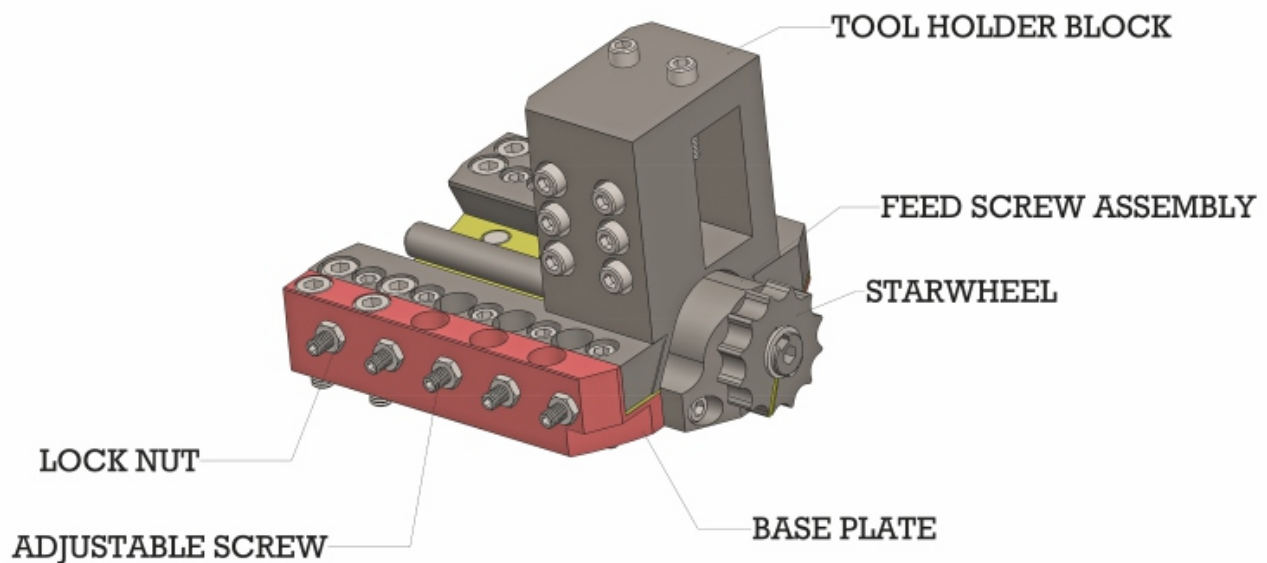
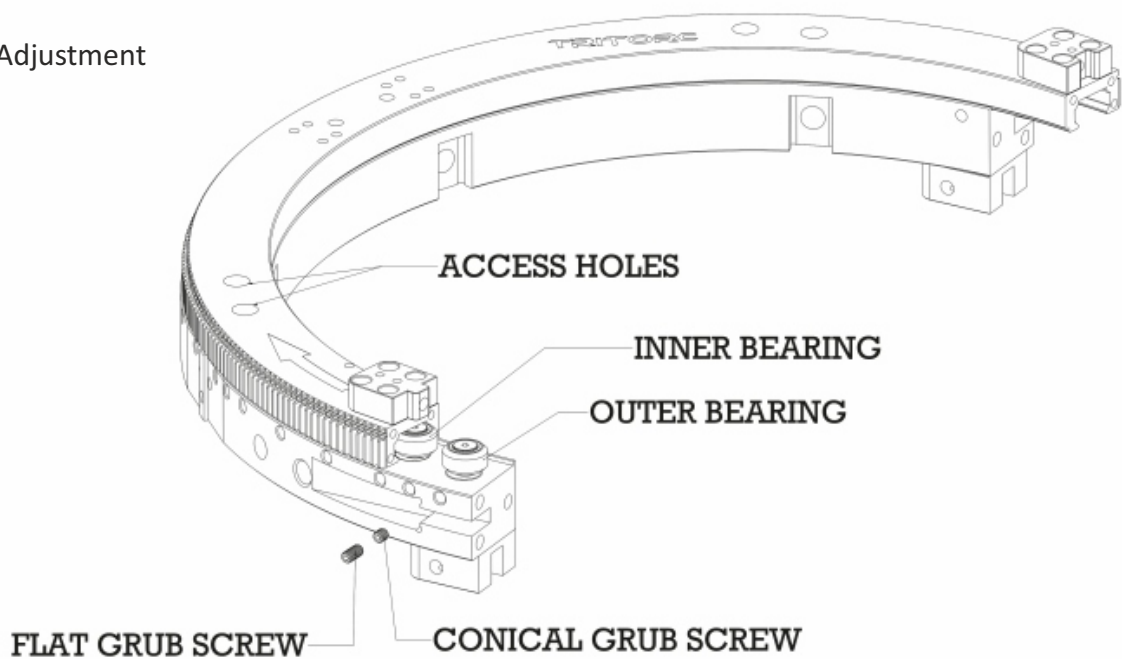

Fig 11. Tool Post Adjustment

ADJUSTING THE BEARINGS:

1. Place the fully assembled machine onto a flat surface, gear side up. Remove the locking pins so the gear can rotate on the housing. Remove the four cap locks from the access holes.
2. Remove the gear shield from the machine. Remove the outer locking setscrews and loosen the eccentric setscrews (see Figure 12, one half shown). Note that some of the eccentrics have locking and eccentric setscrews that are accessed from the ID instead of the OD.
3. Starting at the split line, rotate the gear until the access holes are directly over the top of the first two bearings. One of the bearings is an inner bearing and the other is an outer bearing. Insert an Allen wrench thru the access hole into the top of the inner bearing; turn it clockwise until it is tight against the inner gear wall. Tighten the eccentric screw to lock it in place. Insert the Allen wrench into the top of the outer bearing; turn it counter-clockwise until it is tight against the outer gear wall. Do not turn too hard or the screw on top of the bearing will unscrew and loosen up. Tighten the eccentric screw. Repeat this procedure for the bearings under the opposite side access holes.

Fig 12.
Bearing Adjustment



4. Rotate the gear so the access holes are directly over the next two bearings. Repeat step 3.
5. Repeat step 4 until all the bearings are tight against the gear walls. All bearings will spin if this procedure is done correctly.
6. Slowly run the machine. Looking thru the access holes, verify that all the bearings are turning. Retighten all the bearings that are not turning. Tighten all of the setscrews to lock the eccentric screws. Install the cap locks into the access holes and reinstall the gear shield. Insert the locking pins.

**NOTE: TCSL Feature Adjustable Bearings
that require periodic adjustment and lubrication.**

BILL OF MATERIAL

Sr. No.	Part Number	Description	Quantity
1	Housing	Main Assembly	1
1.1	MA-1	Housing 1	1
1.2	MA-2	Housing 2	1
1.3	MA-3	Rack 1	1
1.4	MA-3	Rack 2	1
1.5	MA-4	Gear shield 1	1
1.5	MA-5	Gear shield 2	1
1.6	MA-6	Rack clamp Male	2
1.7	MA-7	Rack clamp Female	2
1.8	MA-8	Housing Clamp	4
1.9	Eye bolt	M10X85	2
1.10	ALLEN SCREW	M8X80	2
1.11	DOWEL PIN	M10X16	4
1.12	DOWEL PIN	M10X20	6
1.13	DOWEL PIN	M6X16	6
2	ULA	Universal Locator Assembly	(Changes as per machine size)
2.1	ULA-1	ULA Screw	(Changes as per machine size)
2.2	ULA-2	Locator Pad	(Changes as per machine size)
2.3	ULA-3	Pad Support	(Changes as per machine size)
2.4	ULA-4	ULA Scale	(Changes as per machine size)
2.5	ALLEN SCREW	M8X25	(Changes as per machine size)
2.6	ALLEN SCREW	M8X20	(Changes as per machine size)
2.7	ALLEN SCREW CSK	M8X25	(Changes as per machine size)
2.8	DOWEL PIN	M6X20	(Changes as per machine size)
3	Gear Box	Gear Box Assembly	1
3.1	GBA-1	Gear Box Housing Bottom	1
3.2	GBA-2	Gear Box Housing Top	1
3.3	GBA-3	Pinion	1
3.4	GBA-4	Guide Pin	1
3.5	GBA-5	Bush Ring	1
3.6	SKF-HK-4020/4520	Needle Roller Bearing	2
3.7	SKF 6200	Ball Bearing	1
3.8	Gear Box Circlip 48/52	Internal Circlip 48/52	1
3.9	M6x40 Long	Allen Screw	4
3.10	DOWEL PIN	Dowel Ø8x20	2
3.11	ALLEN SCREW	M10x50 Long	2
3.12	ALLEN SCREW	M8X35	2
4	Tripper	Tripper Assembly	1
4.1	TA-1	Tripper Holder	1
4.2	TA-2	Tripper Lock	1
4.3	TA-3	Tripper	1
4.4	TA-4	Tripper Lock Pin	1
4.5	TA-5	Tripper Lock Pin Head	1
4.6	M6x20 Long	Allen Screw	2
4.7	M5x25Long	Allen Screw	1
4.8	M6x25 Long	Allen Screw	1
4.9	M8x40 Long	Allen Screw	3
5	Tool Post	Tool Post Assembly	2
5.1	TPA-AL-1	Base Plate	2
5.2	TPA-2	Lead Screw	2
5.3	TPA-3	Lead Screw Holder	2

BILL OF MATERIAL

Sr. No.	Part Number	Description	Quantity
5.4	TPA-5	Tool Holder	2
5.5	TPA-6	Star Wheel	2
5.6	TPA-7	Lead Screw Bush	2
5.7	TPA-8	Tool Holder Bush	2
5.8	TPA-18	Fix Plate	2
5.9	TPA-19	Moving plate	2
5.10	TPA-20	Guide plate	2
5.11	B27.7M-3BM1-28	External Circlip 28	2
5.12	B27.7M-3BM1-15	External Circlip 15	4
5.13	SKF-51102	Bearing	2
5.14	SKF-61902	Bearing	4
5.15	14x12x7inch	Cutting Tool	1
5.16	M8x40Long	Allen Screw	12
5.17	M8x30Long	Allen Screw	16
5.18	DIN ES ISO 1580	Allen Screw	4
5.19	M5x35Long	Allen Screw	4
5.20	Dowell Ø6x20L	Dowell Pin	4
5.21	Parallel KeyA5x5	Key	1
6	Rotating Assembly	Bearing Shaft assembly	(Changes as per machine size)
6.1	RA-1	Bearing Hub	(Changes as per machine size)
6.2	RA-2	Bearing Casing	(Changes as per machine size)
6.3	RA-3	Bearing Screw	(Changes as per machine size)
6.4	RA-4	Distance Washer	(Changes as per machine size)
6.5	RA-6	Bearing Separator	
6.6	RA-9	Conical Grub Screw	

TROUBLESHOOTING

TROUBLE	POSSIBLE REASON	REMEDY
Machine doesn't work	Locking pin not removed Power supply not on	Remove pins Check the power supply
Machine wave when working	The expansion structure is not fastened or the expanding block wrongly choose	Check the expansion screw or change a proper expanding block
Working face not good	The bevel tool bit is blunt or damaged	Edge the tool bit or replace with new tool bits
Machine chatters during working	Cutting speed too fast (Hydraulic Type)	Slow down the cutting speed
Tool bit easy broken	Machine not perpendicular to pipe	Refer to installation
Reducer Driven gear and Driving gear shaft damaged	Tool bits blunt; Machine not perpendicular to pipe	Edge the tool bit or replace with new tool bits;
Air Motor weak	The motor vane(blade) wear	Replace with new motor vane
Air Motor does not work	Dirt jam; Parts rust	Clean the air motor and adopt the air treatment (air filter / regulator / lubricator) for compressed air
Electric motor abnormal sound	Check the carbon brush or the motor bearing	Replace with new carbon brush or bearing

PART LIST MAIN ASSEMBLY

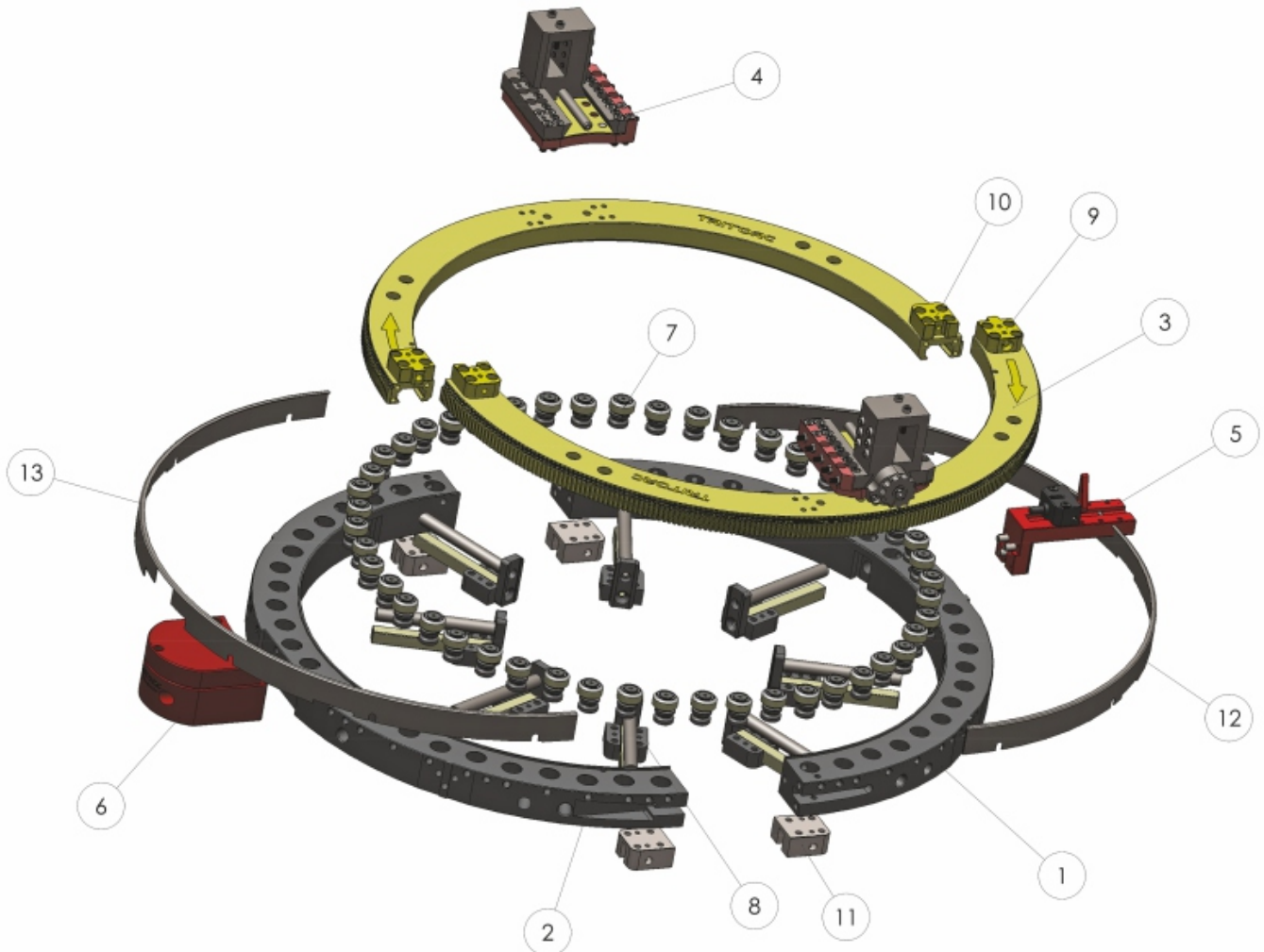

ITEM NO	PART NUMBER	DESCRIPTION	QTY
1	TCSL-24-MA-1	HOUSING 1	1
2	TCSL-24-MA-2	HOUSING 2	1
3	TCSL-24-MA-3	ROTATING RING	2
4	TCSL-TPA-HD-0A	TOOLPOST ASSEMBLY	2
5	TCSL-TA-0A	TRIPPER ASSEMBLY	1
6	TCSL-16_18_20_22_24-GBA-0A-NIR	GEARBOX ASSEMBLY	48
7	TCSL-RA-0A	BEARING ASSEMBLY	2
8	TCSL-ULA-0A	UNIVERSAL LOCATOR ASSEMBLY	8
9	TCSL-4-MA-6	RACK LOCK MALE	2
10	TCSL-4-MA-7	RACK LOCK FEMALE	2
11	TCSL-24-MA-8	HOUSING LOCK	4
12	TCSL-24-MA-4	GEARSHIELD 1	1
13	TCSL-24-MA-5	GEARSHIELD 2	1

GEAR BOX ASSEMBLY

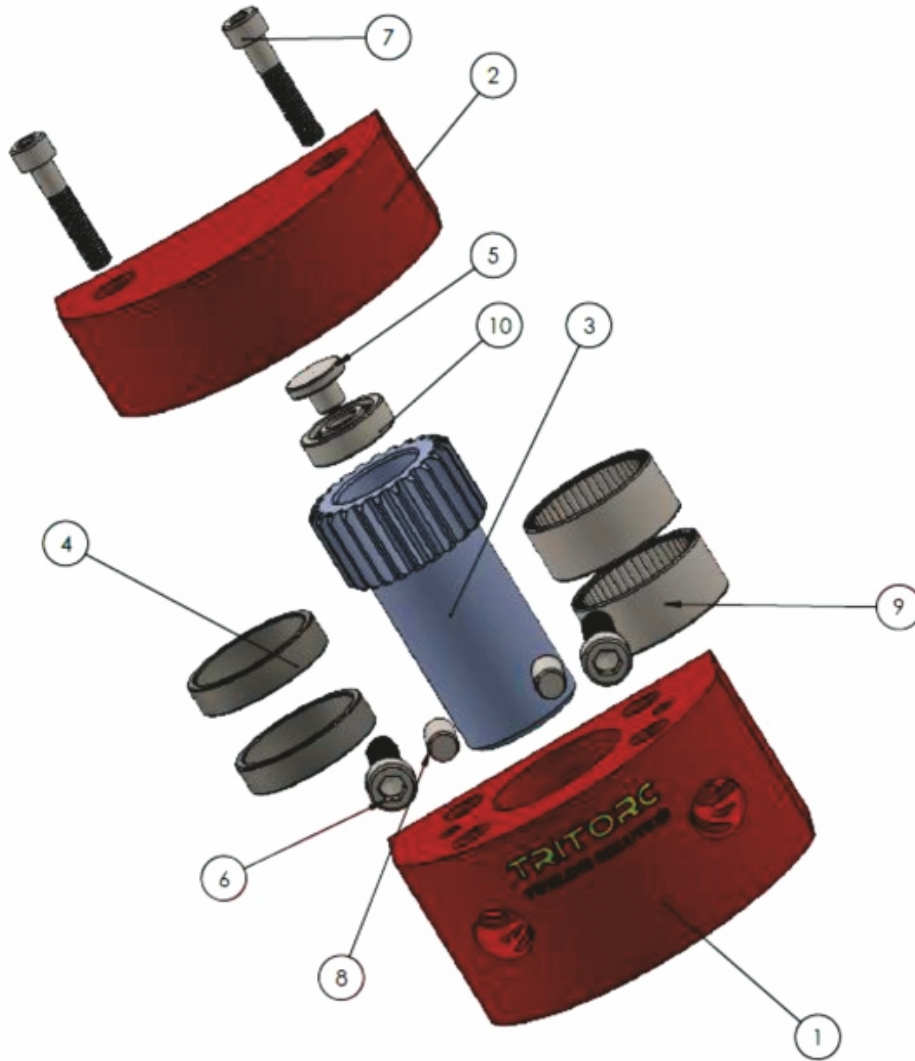

ITEM NO	PART NUMBER	DESCRIPTION	QTY.
1.	TCSL-12-GBA-CH-1	GB HOUSING BOTTOM ATLAS COPCO	1
2.	TCSL-12-GBA-CH-2	GB HOUSING TOP	1
3.	TCSL-12-GBA-CH-3	PINION	1
4.	TCSL-12-GBA-CH-5	PINION BUSH 2	2
5.	TCSL-30-GBA-CH-4	PINION BUSH	1
6.	B18.3.1M - 10 x 1.5 x 40 Hex SHCS -- 40SHX	STD	2
7.	B18.3.1M - 8 x 1.25 x 40 Hex SHCS -- 28SHX	STD	2
8.	DIN EN 28734 - 10 x 22 - A - St	STD	2
9.	SKF - HK 4020 - Full, DE, AC Full	STD	2
10.	SKF - 6200 - Full, DE,AC,Full_68	STD	1

TOOLPOST ASSEMBLY

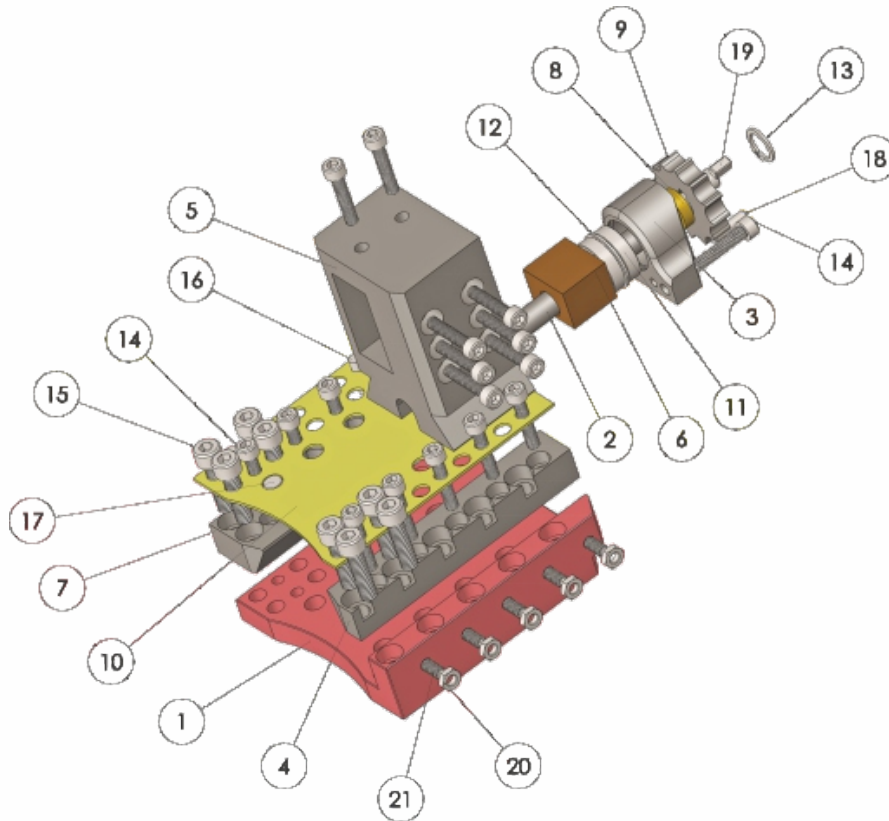

ITEM NO.	PART NUMBER	DESCRIPTION	QTY.
1	TCSL-TPA-HD-1	Base Plate HD	1
2	TCSL-TPA-HD-2	Lead Screw	1
3	TCSL-TPA-HD-3	Lead Screw Holder	1
4	TCSL-TPA-HD-4	Moving Plate HD	1
5	TCSL-TPA-HD-5	Tool Holder HD	1
6	TCSL-TPA-HD-6	Lead Screw Bush	1
7	TCSL-TPA-HD-7	Fix Plate	1
8	TCSL-TPA-HD-8	Lead Screw Holder Bush	1
9	TCSL-TPA-HD-9	Ratchet	1
10	TCSL-TPA-HD-10	Glide Plate HD	1
11	INTERNAL CIRCLIP-28mm BORE DIA		1
12	015 Circlip		1
13	SKF - 61902 - Full,DE,AC,Full_68		2
14	B18.3.1M - 8 x 1.25 x 40 Hex SHCS -- 28SHX		8
15	IS 2393- 6 x 20-DF	Dowel Pin	2
16	key 5X5		1
17	B18.2.4.5M - Hex jam nut, M6 x 1 --D-N	Nut	5
18	M6X30	Allen Screw	2
19	IS 2393- 10 x 20-DC	Dowel Pin	2
20	IS 2393- 5 x 20-DC	Dowel Pin	2
21	B18.3.6M - M6 x 1.0 x 25 Hex Socket Flat Pt. SS --S		5
23	B18.3.1M - 8 x 1.25 x 30 Hex SHCS -- 30SHX		8
24	B18.3.1M - 6 x 1.0 x 25 Hex SHCS -- 25SHX		10

TRIPPER ASSEMBLY

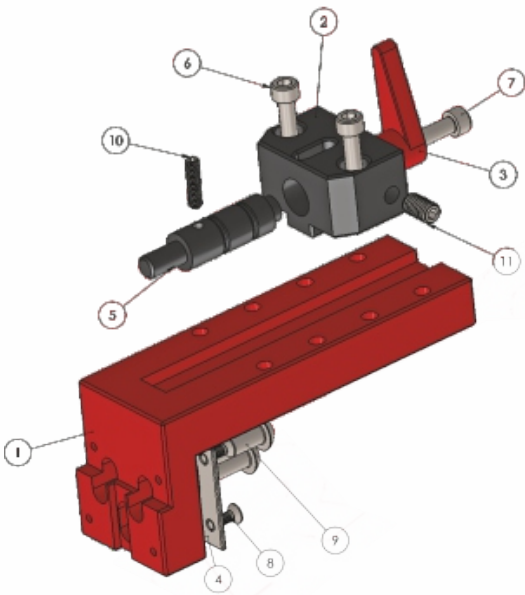

ITEM NO	PART NUMBER	DESCRIPTION	QTY
1	TCSL-TA-1	TRIPPER HOLDER	1
2	TCSL-TA-2	TRIPPER LOCK	1
3	TCSL-TA-5	TRIPPER LOCK PIN HEAD	1
4	TCSL-TA-6	SS COVER	1
5	TCSL-TA-4.2	TRIPPER LOCK PIN	1
6	B18.3.1M - 6 x 1.0 x 35 Hex SHCS -- 24NHX		2
7	B18.3.1M - 6 x 1.0 x 16 Hex SHCS -- 16NHX		1
8	B18.3.5M - 4 x 0.7 x 12 Socket FCHS -- 12S	CSK	4
9	B18.3.4M - 8 x 1.25 x 30 SBHCS --N		3
10	B18.3.6M - M5 x 0.8 x 20 Hex Socket Flat Pt. SS --S		1
11	B18.3.6M - M8 x 1.25 x 16 Hex Socket Cone Pt. SS --S		1

UNIVERSAL LOCATOR ASSEMBLY

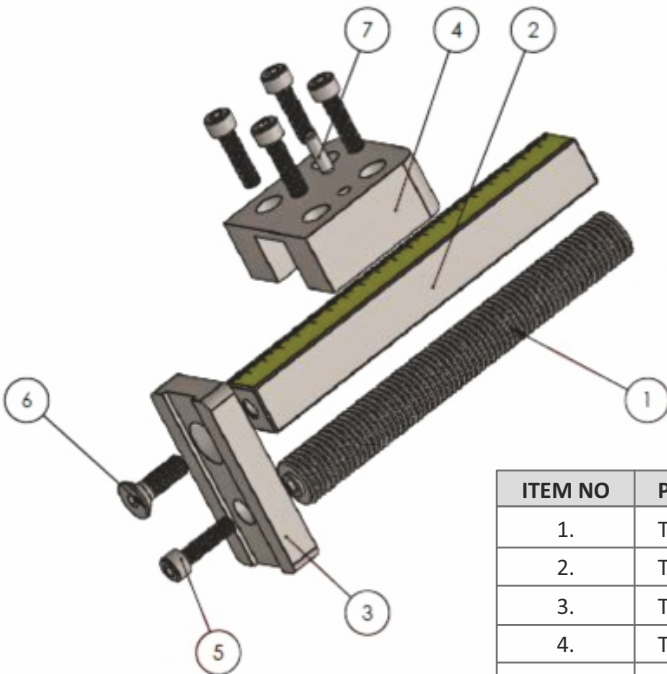

ITEM NO	PART NO	DESCRIPTION	QTY.
1.	TCSL-ULA-1	FLANGE HOUSING LOCK SCREW LONG	1
2.	TCSL-ULA-4	UNIVERSAL LOCATOR PAD SLIDER	1
3.	TCSL-ULA-2	UNIVERSAL LOCATOR PAD	1
4.	TCSL-ULA-.3	LOCATING PAD SUPPORT	1
5.	B 18.3.1 - 3X 0.5 X 12 HEX SHCS—12 SHX	STD	5
6.	B 18.3.5 M - 5 X 0.8 X 16 SOCKET FCHS – 16S	STD	1
7.	DIN EN 28734 - 4 X 20 – A - ST	STD	2

ROTATING ASSEMBLY

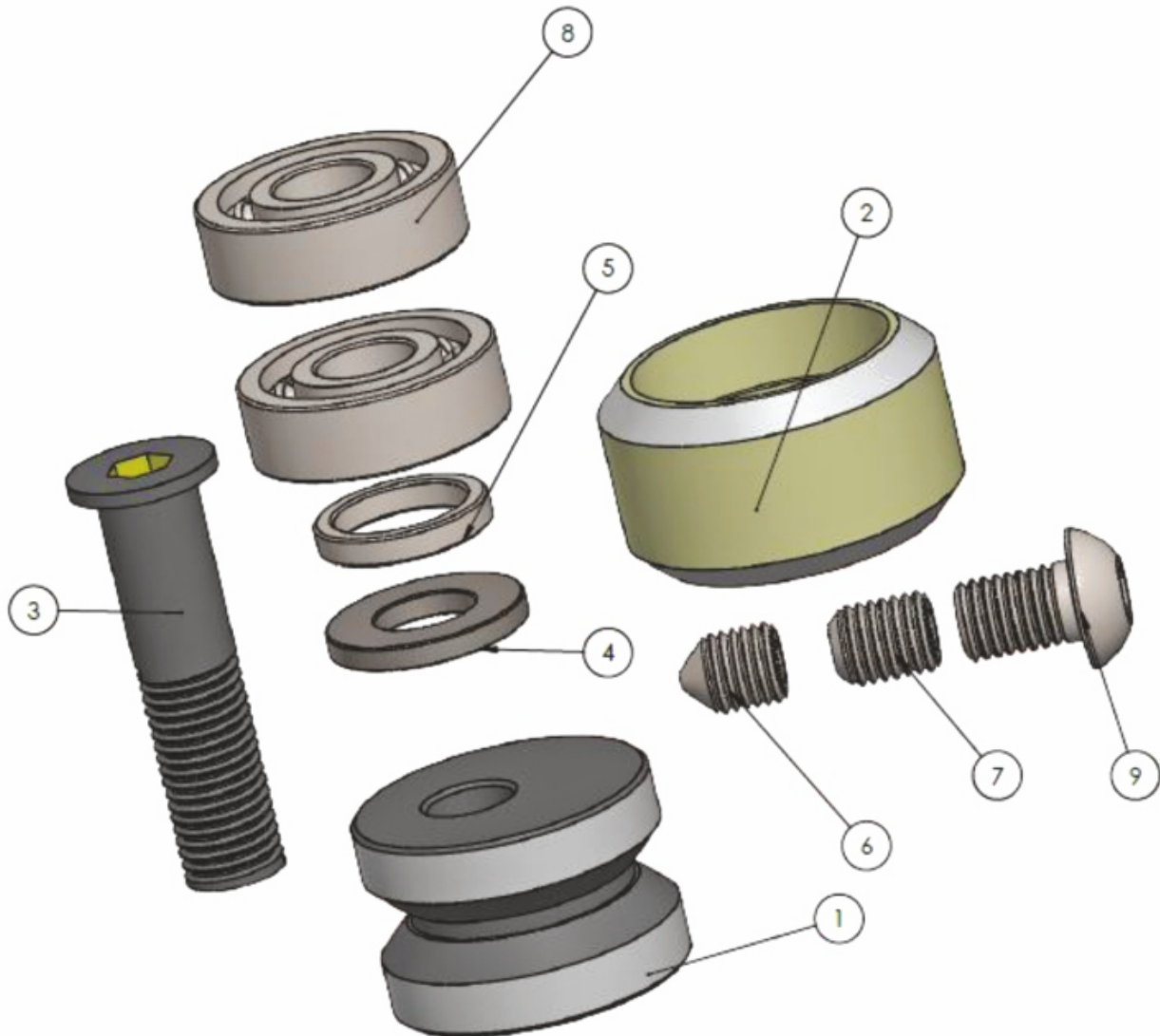

ITEM NO	PART NUMBER	DESCRIPTION	QTY
1.	TCSL-RA-1	BEARING HUB	1
2.	TCSL-RA-1	BEARING CASING	1
3.	TCSL-RA-1	JOINING SCREW	1
4.	TCSL-RA-1	DISTANCE WASHER	1
5.	TCSL-RA-1	BEARING DISTANCE	1
6.	B18.3.6M - M8 x 1.25 x 20 Hex Socket Cone Pt. SS --S	STD	1
7.	B18.3.6M - M8 x 1.25 x 16 Hex Socket Type I Cup Pt. SS --S	STD	1
8.	SKF - 6000 - Full,DE,AC,Full_68	STD	2
9.	B18.3.4M - 8 x 1.25 x 12 SBHCS --S	STD	1

TRITORC

PIPELINE SOLUTIONS



1 Stop for all **Bolting** and **Onsite Machining** Solutions



Pipe Cutting Tool



Bevelling Machine



Square Drive Tool



Hex Drive Tool



Bolt Tensioner

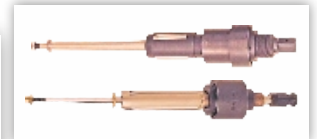

Tube Tools



Bolt Tensioning Services



Re-tubing Services



Valve Repairing / Replacement Services



Bolt Torquing Services



Cold Cutting Services

APPLICATION PICTURES

TRITORC INC 

5041, Spencer Highway, Suite #302,
Pasadena, Texas - 77505. Tel.: +1 (832)-831-4342
E.: info@tritorc.com | W.: www.tritorc.com

+1-281-658-0558
info@tritorc.com | www.tritorc.com

WE ARE ALSO PRESENT IN
INDIA | UAE | KSA | QATAR | NIGERIA | OMAN | KUWAIT | AUSTRALIA