

## OPERATION & MAINTENANCE MANUAL FOR CUSTOMISED TOPSIDE BOLT TENSIONERS (BTL)

### IMPORTANT RECEIVING INSTRUCTIONS:

- Always wear safety gear such as eye protection and gloves, safety shoes, etc. before beginning pump operation.
- It is hazardous to use this high-pressure equipment if you are in doubt regarding its correct assembly and operation.
- It is prudent to use Tritorc supplied equipment that is in good working condition.
- Bolt tensioning equipment machined or modified by anyone other than Tritorc is not to be used.
- All personnel in the immediate vicinity are to be made aware that high-pressure equipment is about to be used and then begin pressurization.
- Ensure the bolt tensioners being used have their pressure holding up as per a normal operation before you approach them.
- Relieve system pressure before you attempt to solve leaks in the system.
- The maximum working pressure is stated on the load cell of the tensioner. The maximum piston stroke of the tool is indicated by a marker band. Do not exceed either of these two limits.

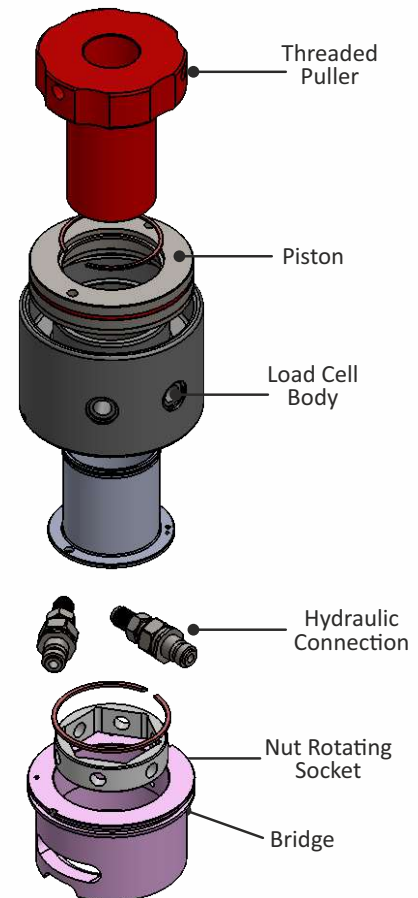

**FAILURE TO FOLLOW THESE INSTRUCTIONS WILL RESULT IN DAMAGE TO THE UNIT OR MAY RESULT IN OPERATOR INJURY OR DEATH.**

### WARNING



All equipment used must be rated for the same operating pressure i.e. 1500 Bar (21,750 psi) **DO NOT** combine high and low-pressure components. If in doubt, contact your Tritorc Technical Expert.

# TENSIONING

Bolted joint requires an evenly distributed load to ensure its integrity. Here, the sequence in which the hydraulic tensioners are applied to the joint is important. To know the exact detail of tensioning sequence and the number of bolts, we must know the number of tensioners available.

## STEP 1:

There must be a sufficient length of the stud protruding on top of the nuts. At a minimum, the length of this protrusion must be 1 X stud diameter. (Refer to illustration no. 2 on the lower right side of this page)

**For example:** for a given bolt size of M25 the minimum required stud protrusion is 25 mm.

## STEP 2:

When the hexagonal nuts do not have holes drilled into their faces, assemble the full tensioner assembly on every alternate bolt that shall be tensioned simultaneously.

Before tensioning begins, ensure that every bolt on the flange is tightened using the tommy bar supplied with the tensioning equipment and that the two halves of the joint are pulled firmly together.

## STEP 3:

The bridge window's position must allow easy access to the nut rotating socket or the hexagon nut. The bridge windows might face radially out from the center of the circular flanged joint.

The bridge must sit flat against the tensioning surface. This can be ensured by examining the circumference of the bridge.

## STEP 4:

The diameter of the bolts, their thread profile and thread pitch must be matched by the threaded puller. Assemble the threaded puller on all of the bolt tensioners by screwing down on the threads protruding above the nut.

Use a tommy bar to fully screw down the threaded puller inserts until contact is achieved with the top face of the load cell.

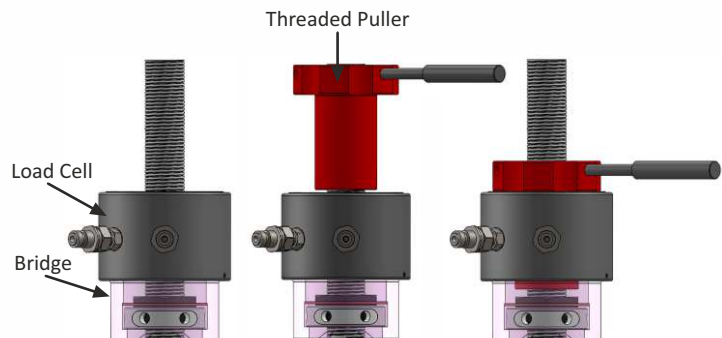
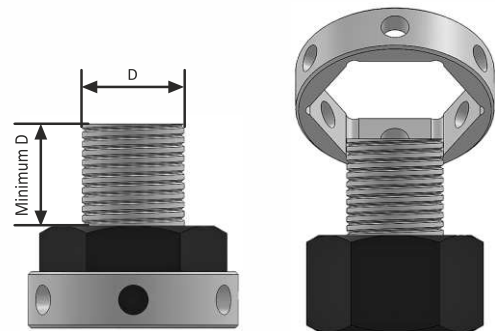

### STEP 5:

The plastic protection caps can now be removed from the male and female quick connect couplings.

Pull back the spring-loaded collar on the female coupling and connect a hydraulic link hose from the pump unit to the first tool.

After inserting a male connector release the female collar and gently tug the link pipe to ensure the hose is connected properly.

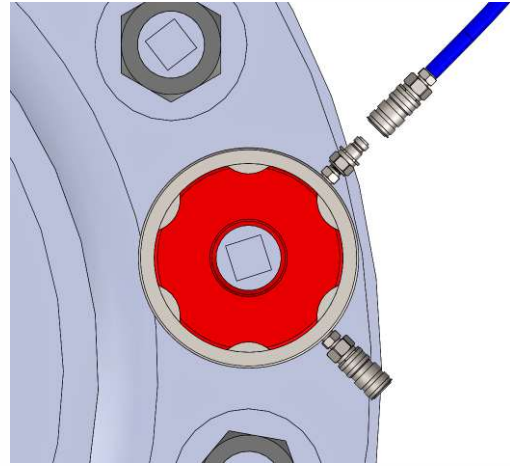

**SAFETY NOTE:** The Link hoses have a maximum working pressure of 21750 psi (1500 Bar).

### STEP 6:

Connect all the tensioners together using link hoses (as shown in the diagram to the left)

The last tensioner might have a female connector that can be left unconnected. One may replace this female connector with a suitable high-pressure blanking plug. (For further details consult Tritorc's Technical experts)

Do not attempt to pressurize an unconnected male Connector.

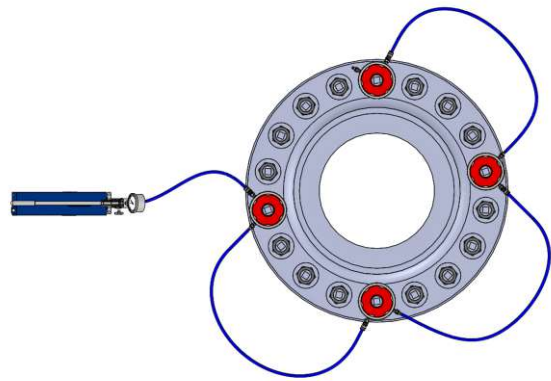

## TENSIONING PROCEDURE

Now that the tensioning system is ready to apply a bolt load to the joint; ensure the following data points are gathered, fully understood and remembered:

- The correct operation of the pump unit.
- The maximum working pressure of the tensioners.
- The maximum piston movement of the tensioners.
- The required working pressure that must be applied to the tensioners.



**Ensure the further Steps (7, 8 & 9) are also understood before the tensioning operation is initiated.**



### STEP 7:

Once the pressurization procedure is initiated, monitor the piston stroke and the pressure constantly as they cannot be allowed to exceed their maximum limits.

If it is observed that the maximum piston stroke is reached before the working pressure is obtained refer to STEP 9 and close the stop valve on the pump unit and then pressurize the system to the required pressure.

When the required pressure is reached, stop the pump by closing off the air supply shut-off valve.

Now the bolts will be initially loaded and the load will be held by the tensioners.

### STEP 8:

Ensure that the pressure is holding firm by checking the pump and the pressure gauge. If it is observed the pressure is stable you are free to approach the tensioners. Now using a Tommy bar, rotate the nuts through the bridge access windows back down towards the face of the joint. The nuts must be firmly seated against the joint by the use of a mallet and tommy bar. If not seated firmly the tensioning procedure will take much longer to complete.

Do not miss any nut while tightening and it is prudent to follow a sequence while doing so.

### STEP 9:

Gradually release the 'return to tank' valve on the pump. This way the load would now be transferred from the tensioners to the nuts.

Assist the pistons by using a tommy bar on the threaded puller.

In case the desired pressure has not been reached, continue from STEP 6 and disconnect all the hydraulic link hoses and reposition the tensioners on the remaining half of the bolts on the flange yet to be tensioned, and continue from STEP 4.

### SEQUENCE:

Usually, the correct Tool to Bolt Ratio is 50%, in certain cases a 25% Ratio is acceptable or one can even choose a minimum of 4 tensioners diametrically on a flange.

Generally, the lower the tool/bolt ratio, the more time will be taken by the tensioners to close the joint properly.

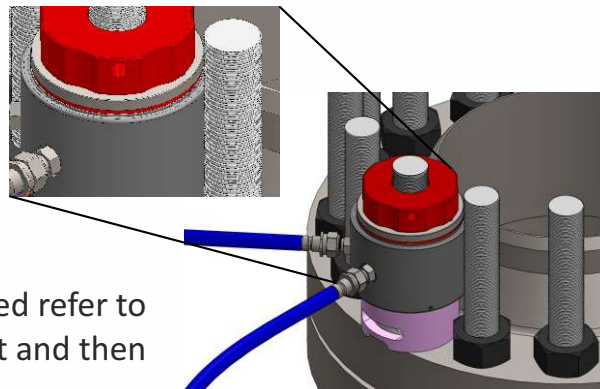

Max Piston Stroke is indicated by a Red Line around the top of the Piston. Stop the pump immediately if this becomes visible.

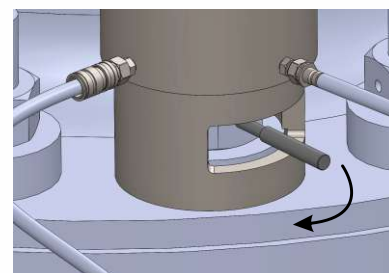

## TRITORC EQUIPMENTS PVT. LTD.

Kripam House, Plot No. A-158, Road No. 25, Wagle Industrial Estate, Thane - 400604, INDIA. Tel.: 022 - 4126 6028.  
E-Mail: enquiry@tritorc.com | Web: www.tritorc.com